

**PV-ZERO LIQUID-FILLED PRESSURE / VACUUM VENT VALVE
PERIODIC MAINTENANCE
(Per Executive Order(S) VR-101, 102, 104 & 105)**

Date of inspection: _____ **Signature** _____

Maintenance Interval, every 12 months:

- A. Visually inspect the housing (1), Pipe fittings (5, 6), and rain cap (2) for obvious signs of damage, missing parts or fluid leaks.
- B. Visually inspect the rain cap, from ground level for signs of bird nests or insect activity.
- C. *Drain and inspect the fill fluid per the Fluid Inspection Procedure (below).
- D. *Perform the Field Testing Procedure- TP 201.1E (recommended).

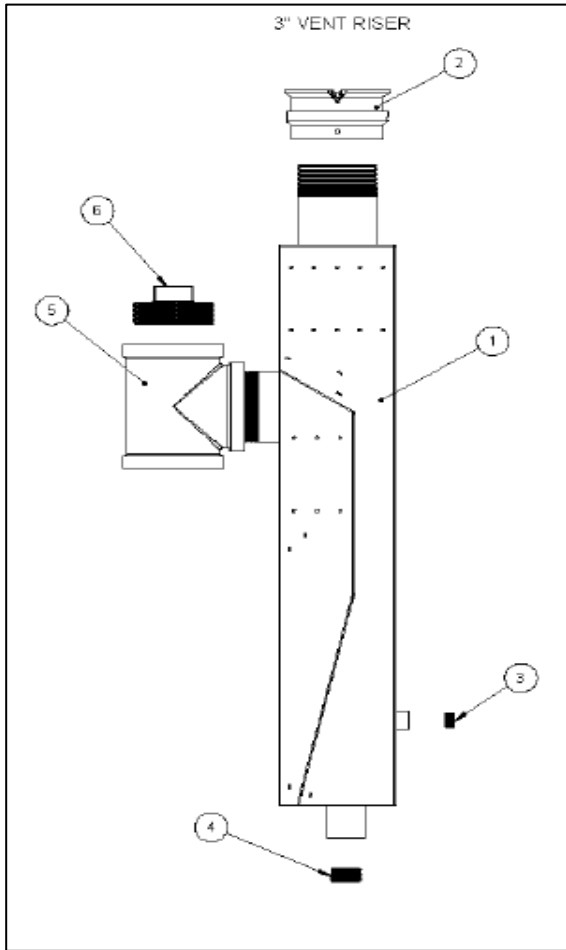

Fluid Inspection Procedure

- 1. Remove the 3" NPT plug (6) from the top side tee (5).
- 2. Remove the 3/8" NPT side plug (3).
- 3. Remove the 1" NPT bottom plug (4) and drain the fluid into a clean, transparent container.
- 4. Visually inspect the fill fluid for debris or water contamination. Since the specific gravity of the fluid is slightly less than water, any water in the fluid will settle to the bottom. The fluid can be reused indefinitely as long as it is free of sediment and water.

Note: Clean fluid can be refilled into the valve and topped off with new fluid, or it can be completely replaced with new fluid.

- 5. Reinstall the 1" NPT bottom plug.
- 6. Refill the PV-Zero valve with fluid through the side-port until it spills out of the port. This is the correct fill level of 1.6 liters (54 oz).
- 7. Reinstall the 3/8" NPT side plug.
- 8. *Perform the Field Testing Procedure (recommended to help ensure leak tightness).
- 9. Reinstall the 3" NPT plug in the top of the side tee.

***Fluid drainage, inspection, handling & replacement and PV-Zero testing must be done by a certified technician. Maintenance and testing technicians must possess the ICC certification for Vapor Recovery System Installation and Repair, in addition to appropriate equipment manufacturer credentials.**